

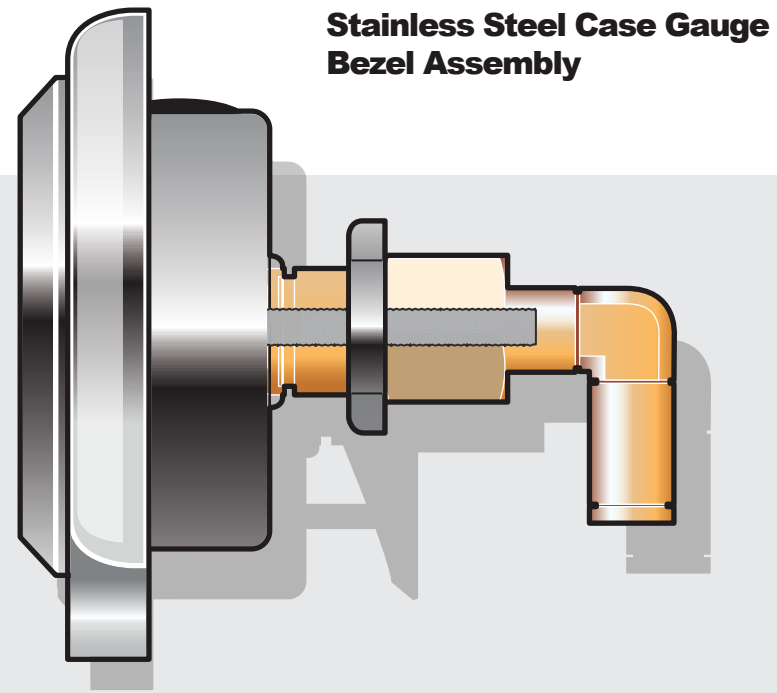

Curve Gauge Bezel
Color Label

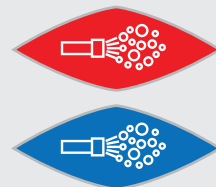

Stainless Steel Case Gauge
Bezel Assembly



Optional Foam or CAFS insert labels

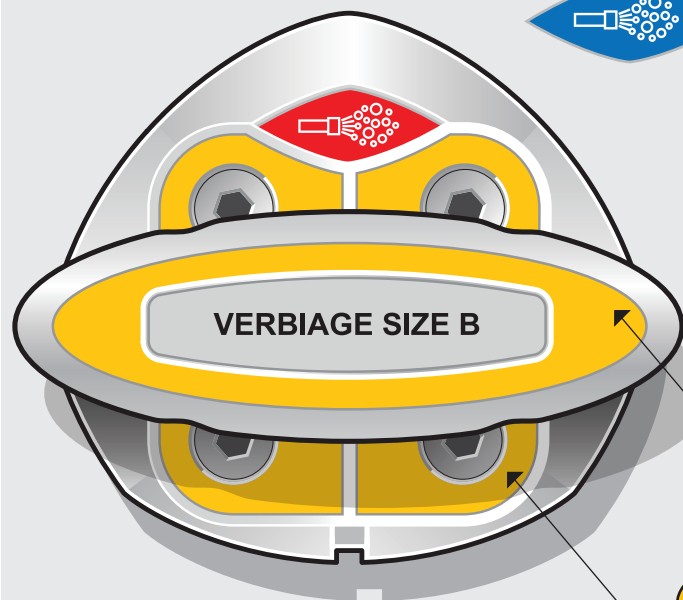

Curve Series Side Mount Valve Control

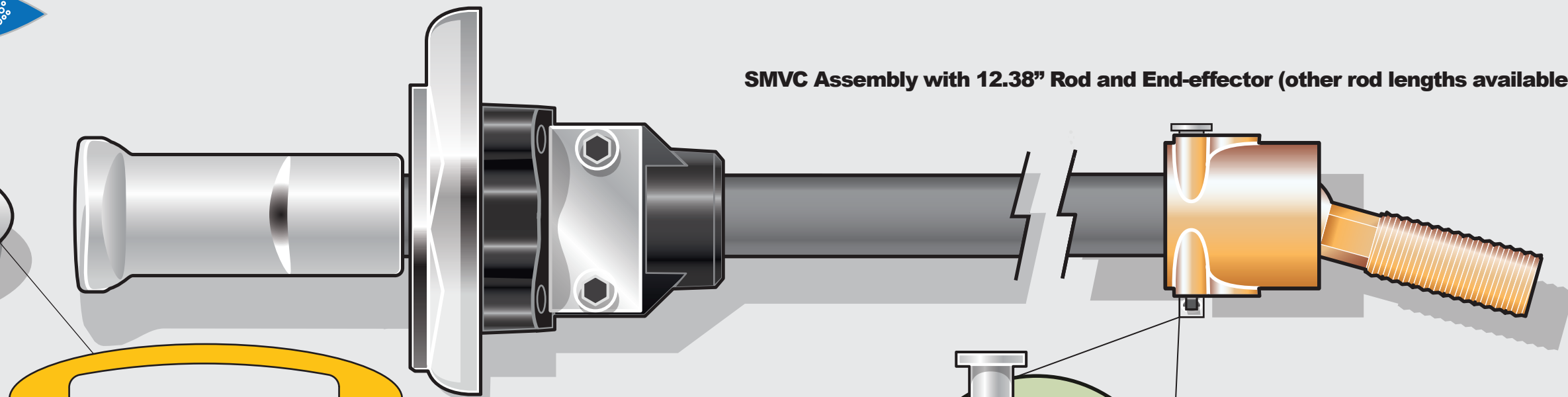

SMVC Assembly with 12.38" Rod and End-effector (other rod lengths available)

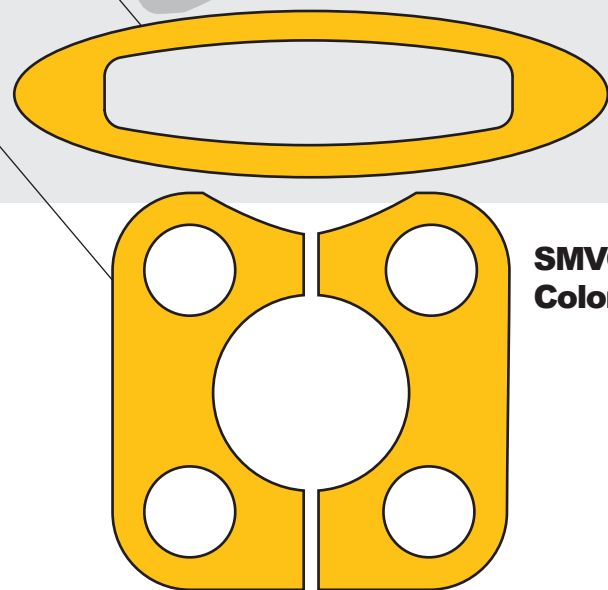

SMVC Curve Bezel
Color Insert Kit

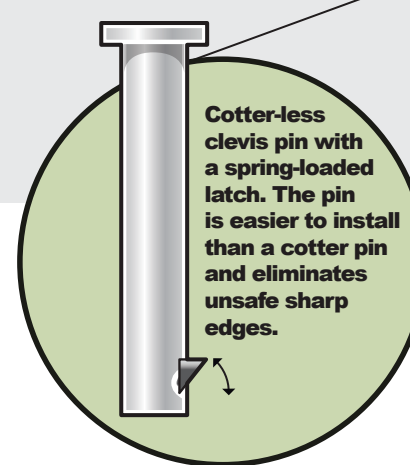

Cotter-less
clevis pin with
a spring-loaded
latch. The pin
is easier to install
than a cotter pin
and eliminates
unsafe sharp
edges.

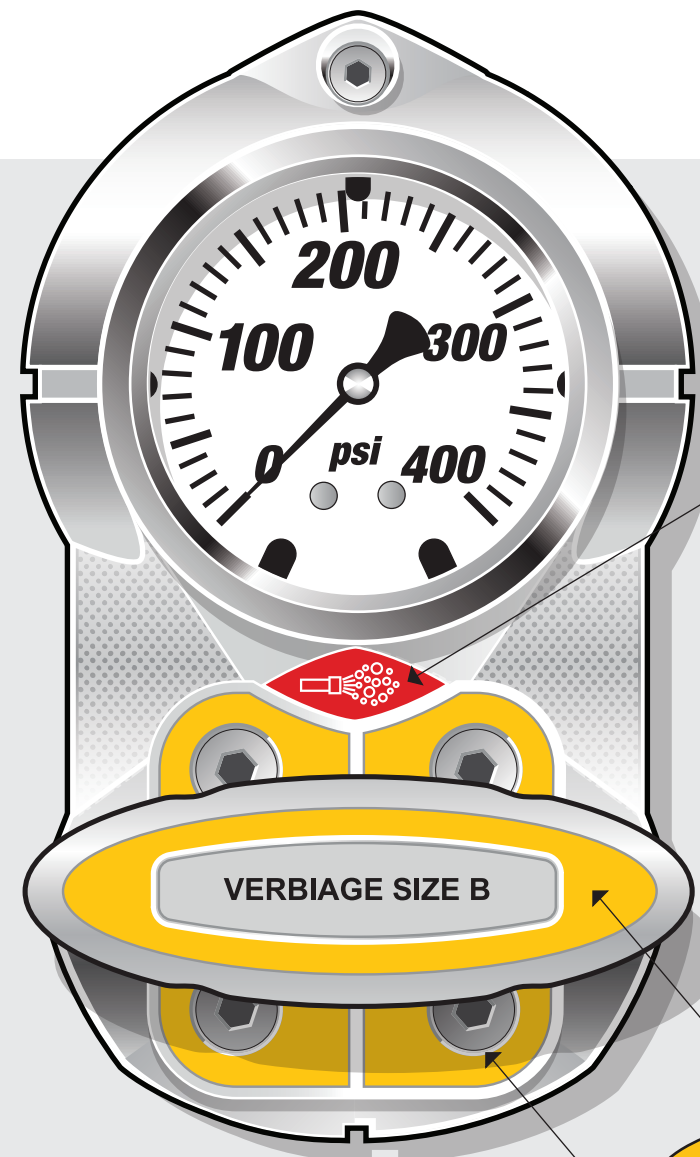

Optional Foam or
CAFS insert labels

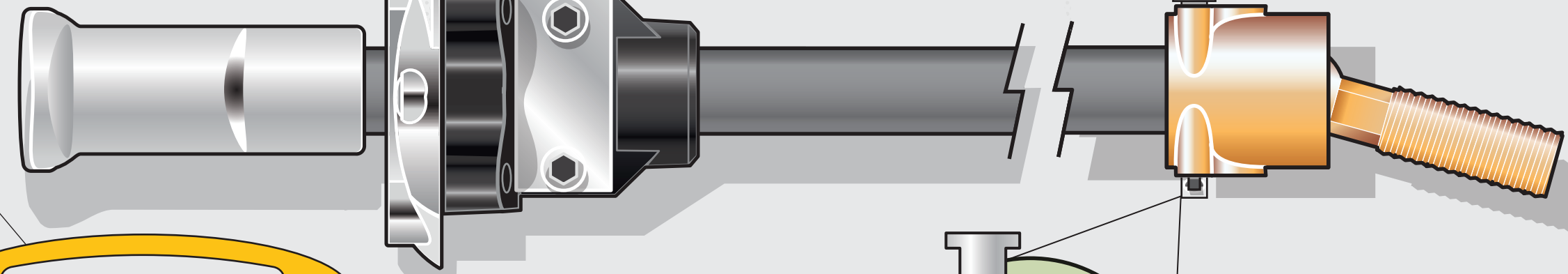
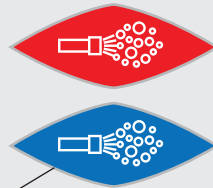

**Integrated Stainless Steel Case Gauge
SMVC Assembly with Rod and End-effector**

various rod lengths available

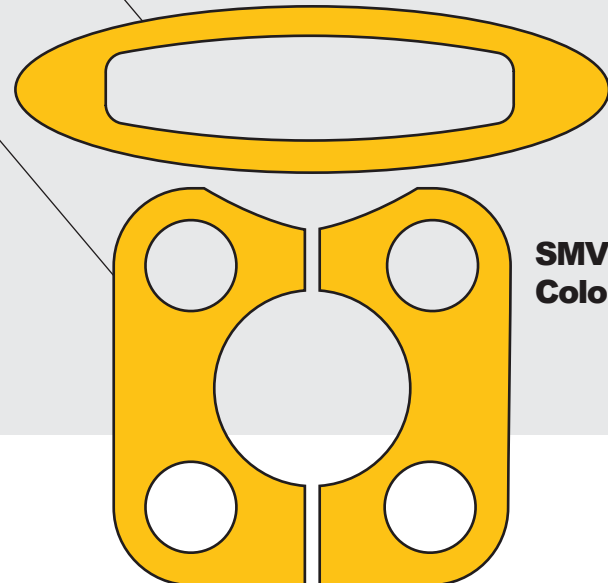

**SMVC Curve Bezel
Color Insert Kit**

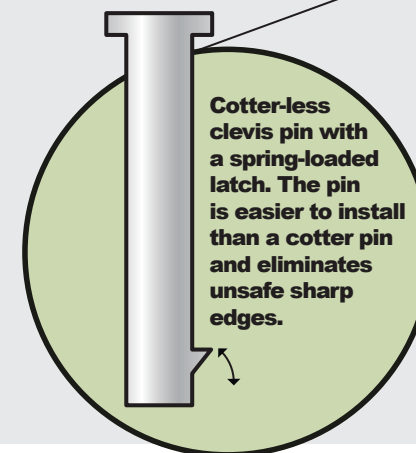

Cotter-less
clevis pin with
a spring-loaded
latch. The pin
is easier to install
than a cotter pin
and eliminates
unsafe sharp
edges.

**Curve Series Integrated
Side Mount Valve Control**



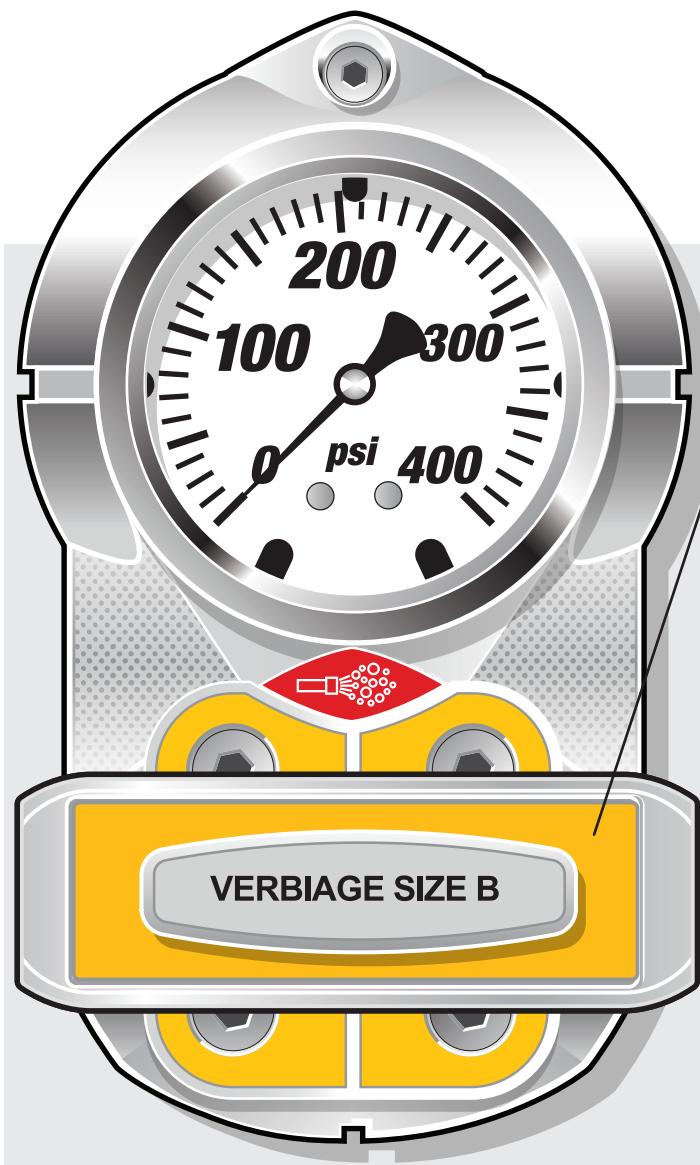

Molded Plastic Verbiage Tag Insert Bezel with Color Coded Label

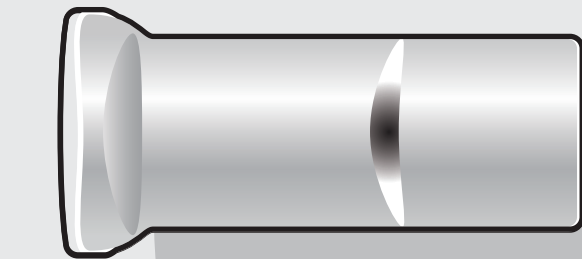

1" x 3" Color Coded Verbiage Label

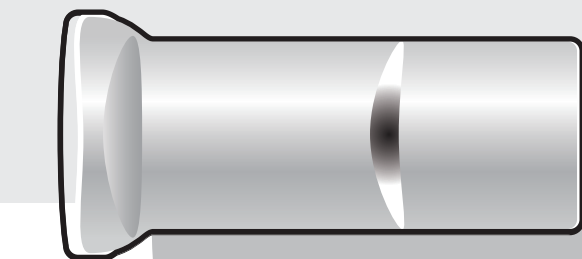
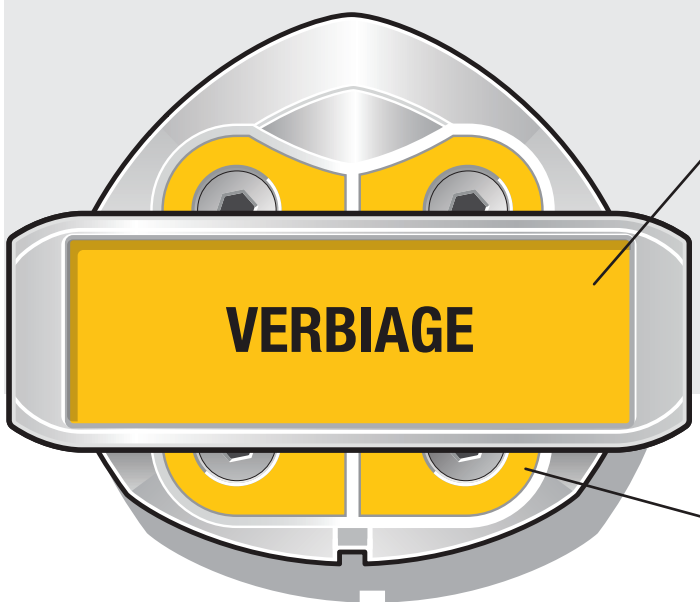

SMVC Color Label Kit

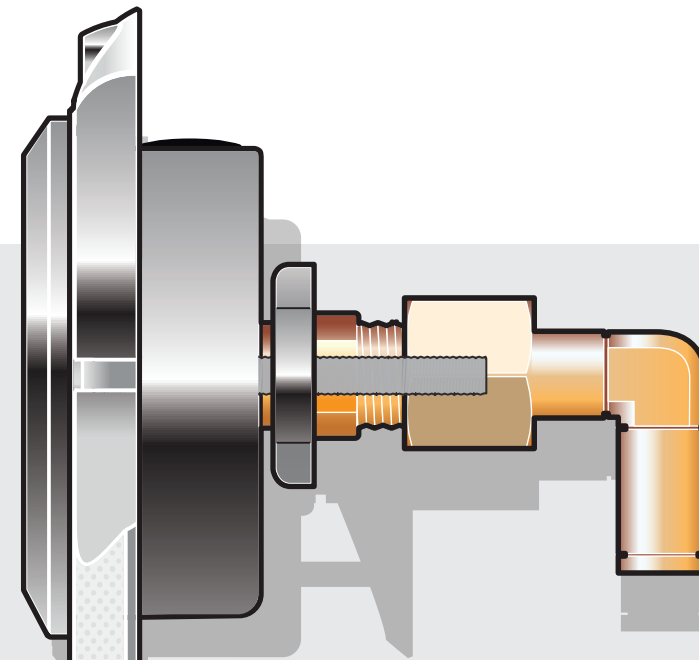

Integrated Stainless Steel Case Gauge SMVC Assembly with 12.38" Rod and End-effector (other rod lengths available) and Large T-Handle for 1" x 3" Verbiage Insert

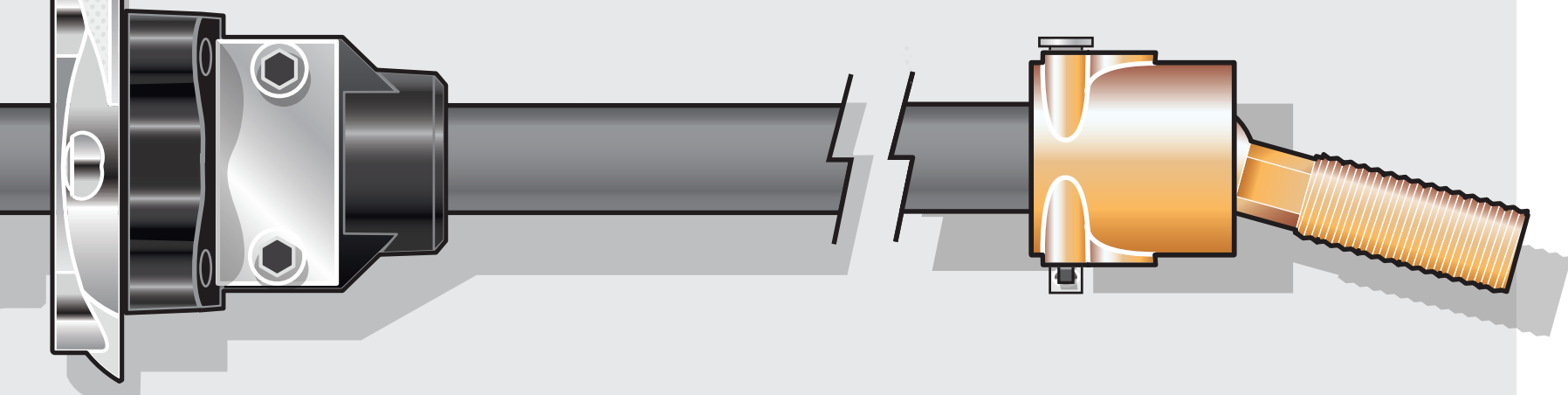

SMVC Assembly with 12.38" Rod and End-effector (other rod lengths available) and Large T-Handle for 1" x 3" Verbiage Insert

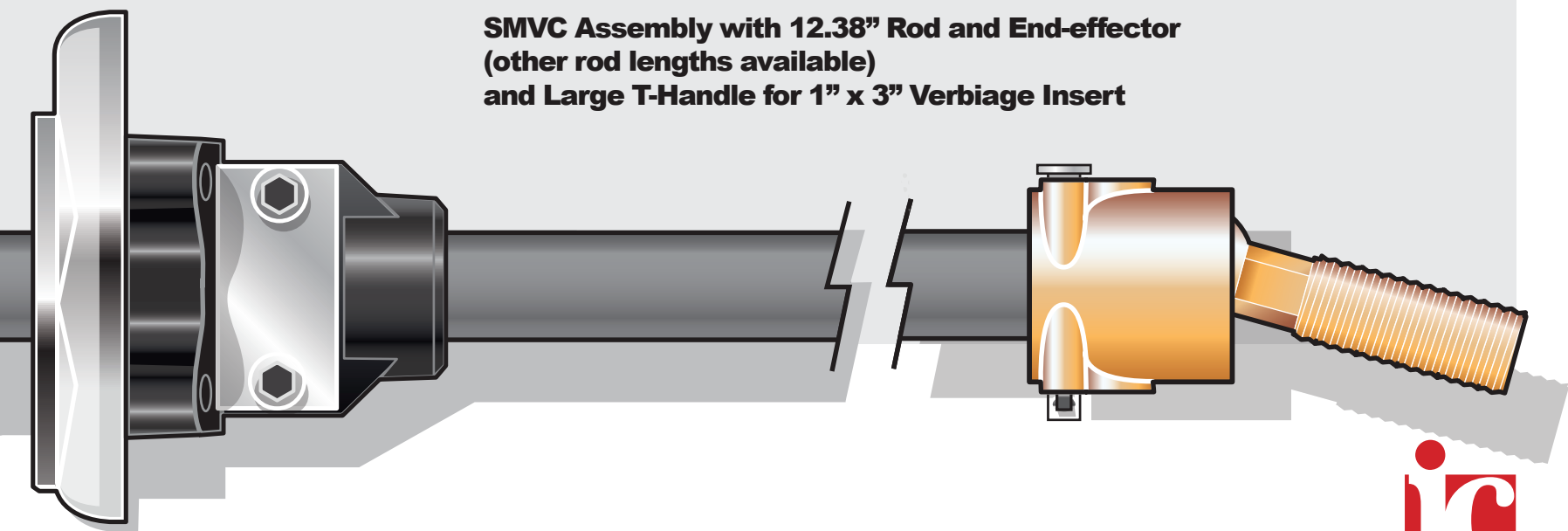

Curve Series Side Mount Valve Control with Large T-Handle for 1" x 3" Verbiage Insert



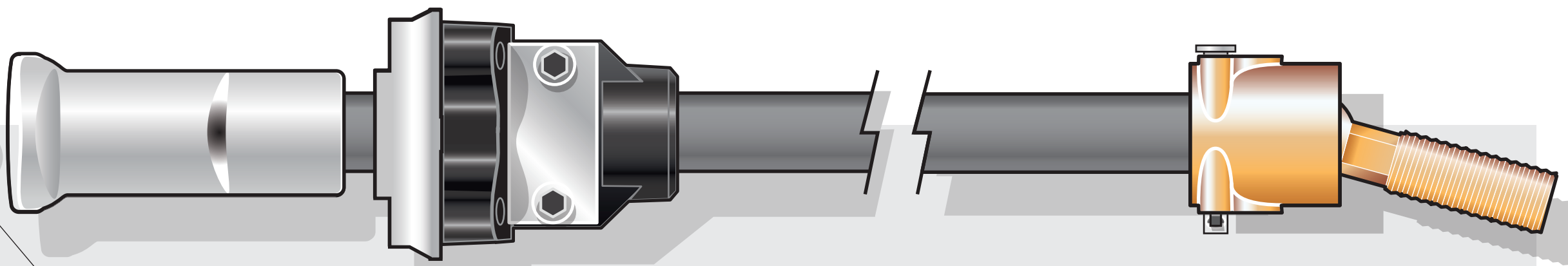
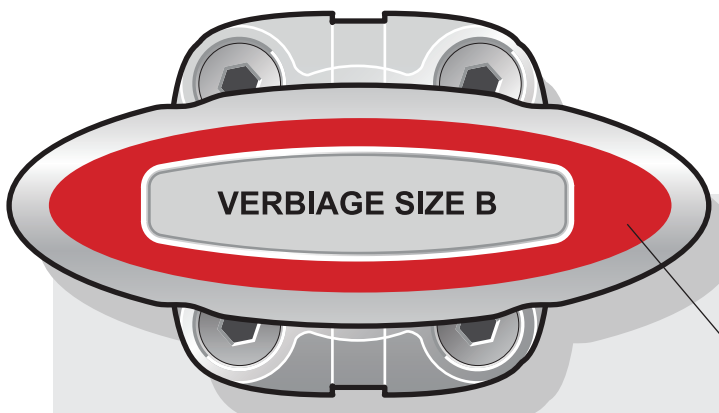

T-Handle Color Insert Label

Side Mount Valve Control Assembly with Rod and End-effector
Various rod lengths available

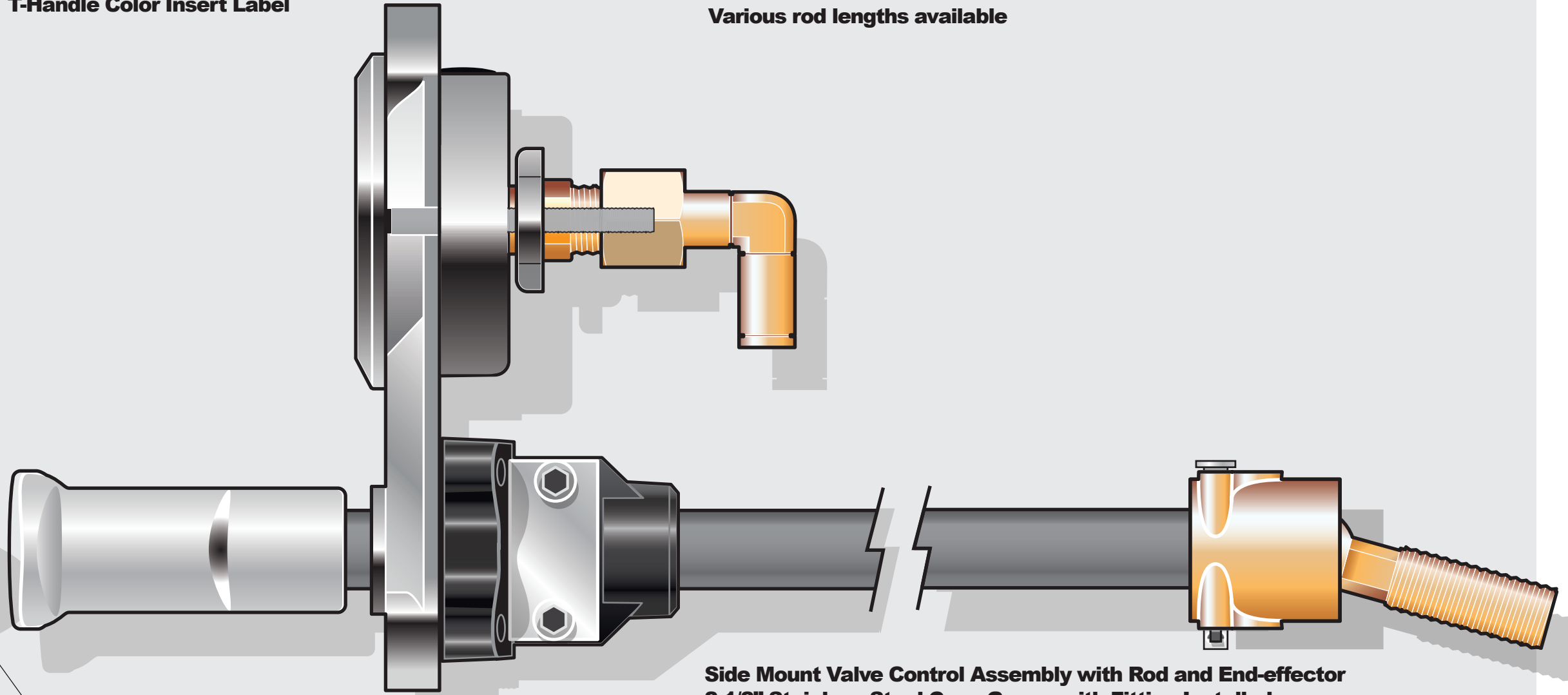
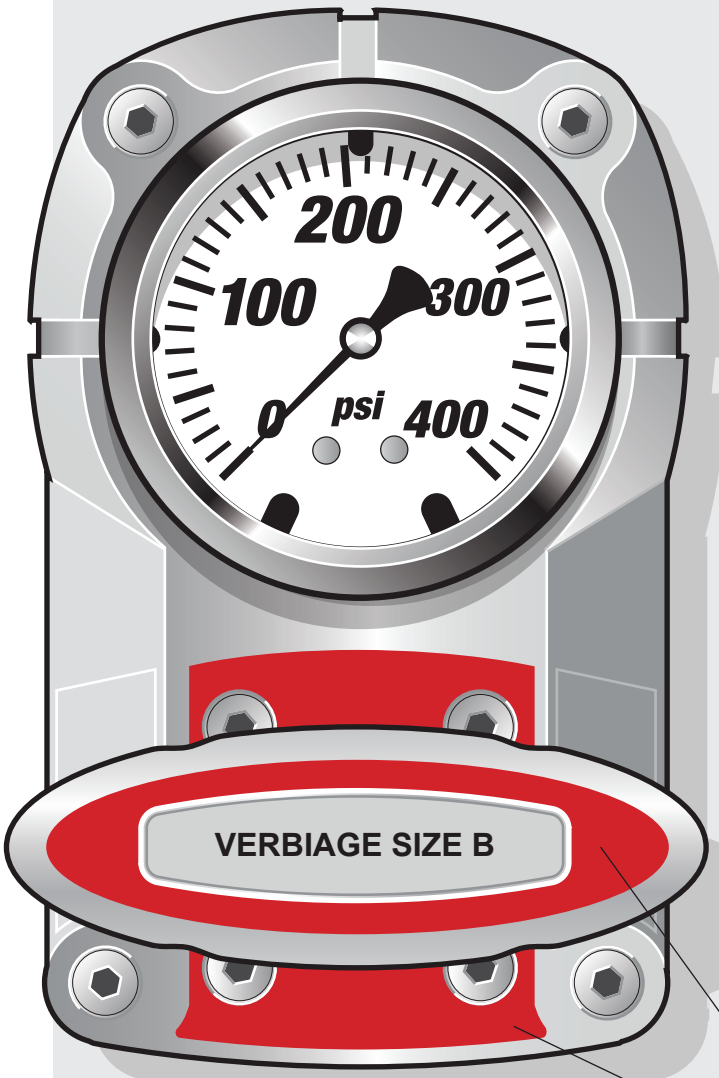

SMVC Color Insert Label Kit

Side Mount Valve Control Assembly with Rod and End-effector
2 1/2" Stainless Steel Case Gauge with Fitting Installed

Innovative Controls Swoop
Side Mount Valve Controls
Aluminum Movement



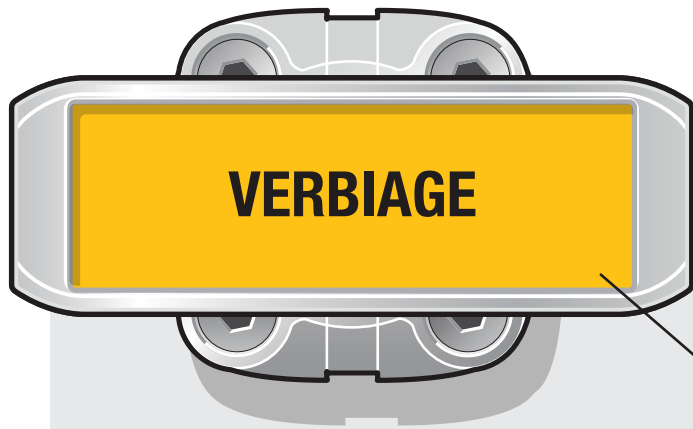

1" x 3" Color Coded Verbiage Label

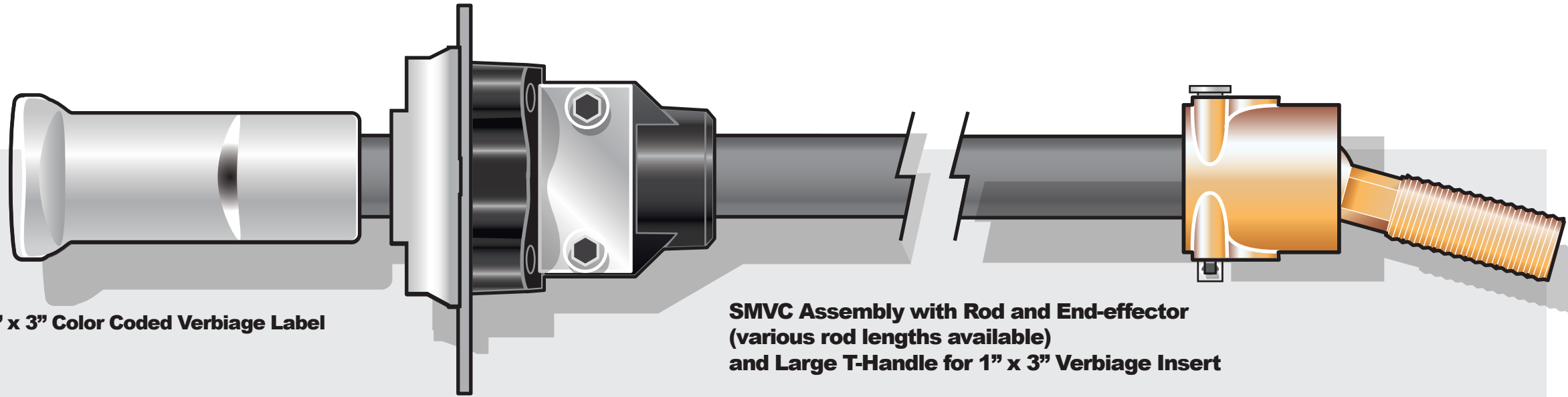

SMVC Assembly with Rod and End-effector (various rod lengths available) and Large T-Handle for 1" x 3" Verbiage Insert

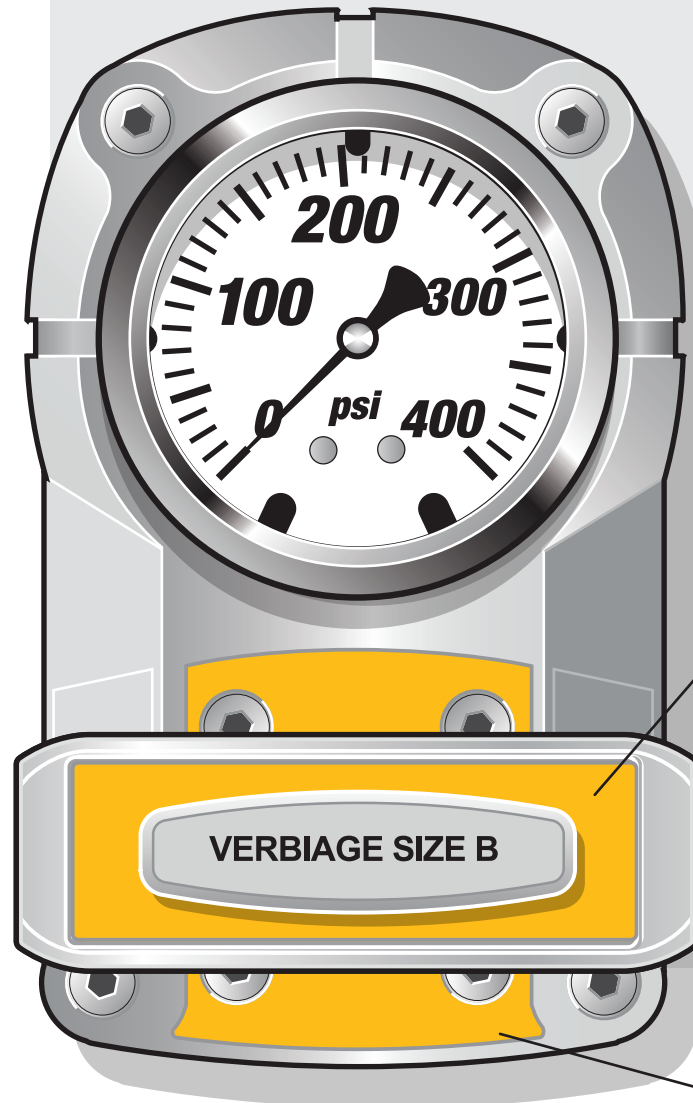

Molded Plastic Verbiage Tag Insert Bezel with Color Coded Label

SMVC Color Label

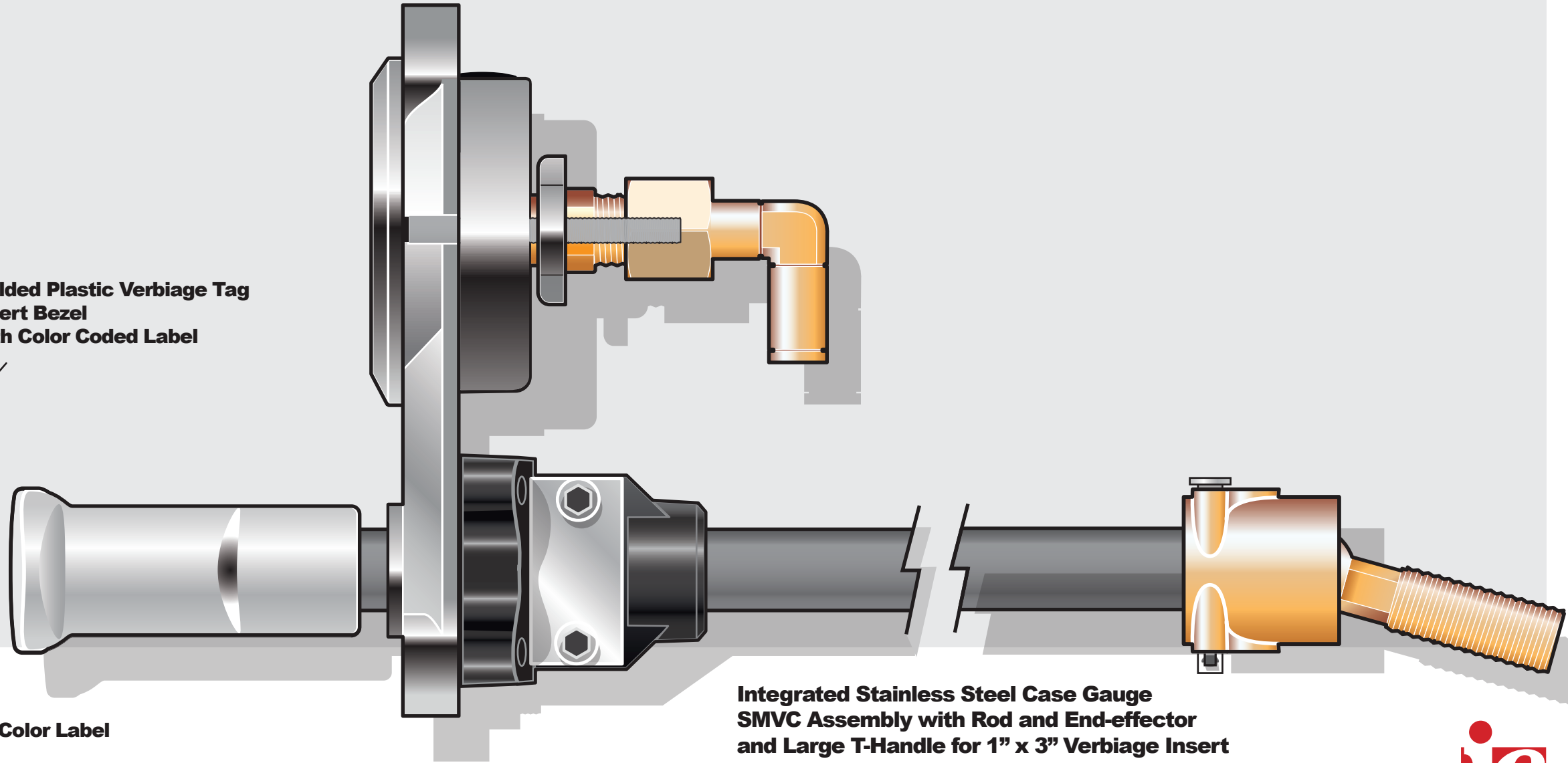

Integrated Stainless Steel Case Gauge SMVC Assembly with Rod and End-effector and Large T-Handle for 1" x 3" Verbiage Insert

Swoop Series Side Mount Valve Control with Large T-Handle for 1" x 3" Verbiage Insert

